



## 4-Stroke Header Installation Instructions

Thank you for choosing FMF as your performance aftermarket exhaust. We have spent countless hours of R&D and testing to ensure you receive the highest quality product on the market today.

All FMF products are developed using the most current technology available for design and manufacturing. Every exhaust is made 100% at the Flying Machine Factory in Southern California. We use only the highest quality American materials for function and durability.

Since 1973, FMF has been bringing you the very best in bolt on performance. Our products are specifically engineered to broaden your existing powerband and give you an all around power increase with substantial weight savings. Bolt on FMF and **FEEL THE POWER!**

Check out our website at [www.fmfracing.com](http://www.fmfracing.com) for more information.

### Attention

This product is designed for closed course use only unless otherwise stated and not intended to meet emission regulations for use on public lands, roads or access routes – consult with local jurisdictions.

Please read all instructions thoroughly before installation. Failure to follow all installation instructions will void any warranty implied or otherwise. FMF Racing is not responsible for problems due to improper installation and/or improper use.

Before you begin installing this product, we recommend wearing safety glasses and mechanics gloves. You must know how to remove and replace your stock exhaust in order to install this FMF product otherwise have it installed by a professional mechanic. Keep all stock parts from your existing system as some components may be necessary to install your new FMF exhaust depending on the application.

### Parts Supplied

- |                           |  |
|---------------------------|--|
| (1) FMF Header (2-pieces) | 044439-044440, 044446-044447,<br>144083-144084 |
| (2) spring                | 980083   |

### Tools Required

- 10, 12, 14mm wrenches
- Phillips screwdriver
- spring puller
- contact cleaner
- high temp silicone

### Removal

1. Make sure the engine is completely cool prior to installation and the vehicle is in a stable position.
2. Remove the muffler (see instructions for removing muffler or refer to your service manual).
3. While not necessary, it is recommended to remove the left-rear motor mount to facilitate header removal.
4. Remove the heatshields from both sections of the stock header – the leading section A on the left side and the trailing section B on the right side. Be careful not to lose the insulating washers under the shields and mounting bolts. Save all parts for later use.
5. Loosen the band clamp on the left side of the motor connecting the two header sections together.
6. Remove the bolt mounting header section B to the front of the engine; save for later use.
7. Remove the nuts attaching header section A to the exhaust port; keep for later use. NOTE - Keep the existing exhaust port gasket as it will be reused if in good condition (minimal cracks, no tears) otherwise replace with a new gasket.
8. Remove header section A by gently sliding it off the exhaust port studs and separating from header section B. Remove header section A from leftside of vehicle.
9. Remove the band clamp from header section B then slide it out the right side of the vehicle.

### Pre-Installation

10. Using contact cleaner clean the exhaust port and gasket to remove and residue or debris. Allow to dry completely. Reinstall gasket.

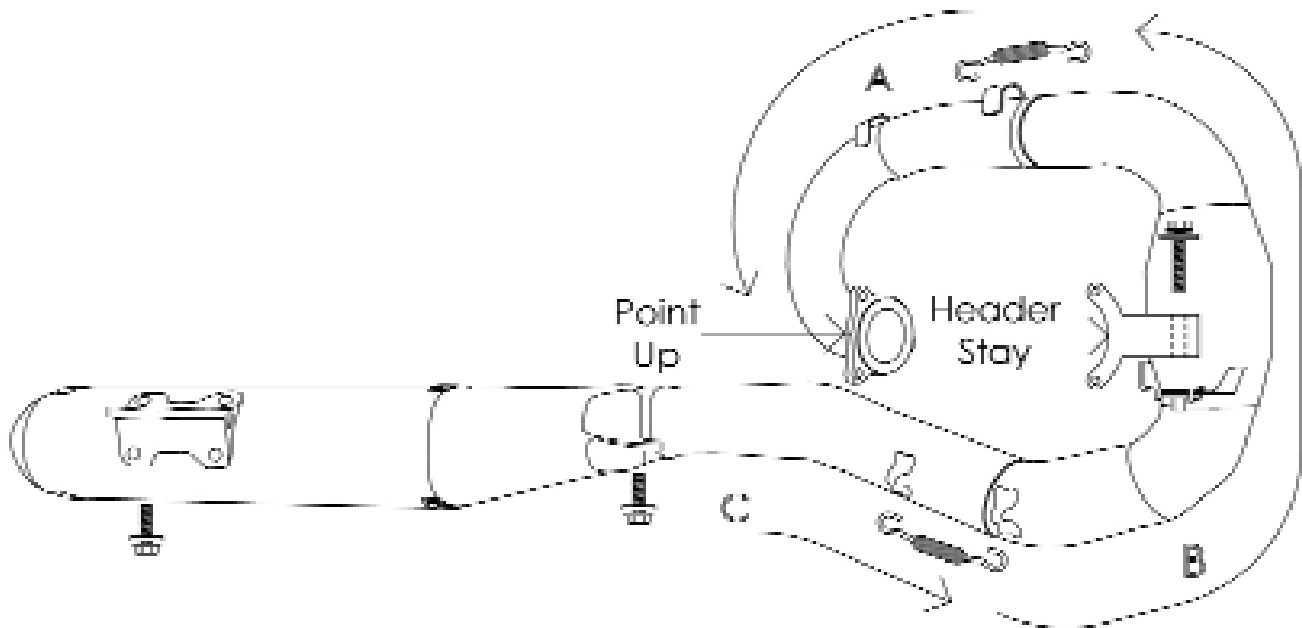

### Installation

11. Align the FMF header section B into position through the right side of the vehicle.
12. Lightly coat the FMF header section A where it connects with header section B with a bead of high temp silicone for an improved seal.
13. Install header section A by aligning with exhaust port and mating with header section B. Slide the mounting flange over the exhaust port studs with the indicator point on the flange pointing up. Thread on the nuts removed in step #7 finger tight. Wipe off any excess silicone.
14. Install header section B using the bolt removed in step #6. Do not tighten at this time.
15. Install the muffler at this time using the instructions provided but do not fully tighten the mounting hardware.
16. Install a supplied spring using a spring puller to connect header sections A and B at the left side of the motor, and another spring to connect section B to the muffler midpipe.
17. Make sure the header and muffler are in neutral positions and not binding. Reinstall the left-rear motor mount if removed in step #3. Slowly tighten all mounting fasteners and clamps to manufacturer's specifications, starting at the exhaust port and working back to the muffler.
18. Install the stock heatshield removed from header section A in step #4 using the stock bolts. Be sure to use the stock insulating washers in the same orientation as they were removed.
19. Inspect the complete exhaust to make sure there is no contact with the frame, shock spring, engine, body panels, or any cables, hoses, or wiring. The exhaust system should only be in contact with the exhaust port and mounting points. Confirm all controls operate in accordance with the manufacturer's specifications.
20. We recommend using high temp silicone for an improved seal. Please follow instructions for the silicone and allow sufficient time to dry before starting the engine.
21. Start the engine and bring it up to operating temperature. Check for exhaust leaks.
22. Let engine cool completely and re-torque all mounting hardware to manufacturer's specifications.

**DISCLAIMER:** All products manufactured and/or distributed by FMF Racing are a) intended for use on stock vehicles specific to the U.S. market; b) for closed course use only unless otherwise stated and c) not intended to meet emission regulations for use on public lands, roads or access routes – consult with local jurisdictions. FMF Racing makes no claims as to the products applicability, effectiveness or fitment on modified machines. FMF Racing is the sole determiner of abuse, misuse, installation errors and modifications. We assume no liability for any errors in listings, specifications, part numbers, prices or model applications. We reserve the right to change specifications, product descriptions, product quality, pricing and application at any time without notice and without further obligation. Buyer assumes all risk for any and all damage caused to themselves, a third party and/or property by virtue of failure of these products. By installing and/or using an FMF product, you hereby accept and understand these stated terms and conditions and have followed all instructional steps.

**LIMITED WARRANTY:** All merchandise manufactured by FMF Racing has a warranty against manufacturing defects for a period of one (1) year from the date of invoice. Warranty is limited to the repair or replacement of defective products. There is no warranty for normal wear and tear, any type of crash damage or for product failure due to improper muffler or packing maintenance. FMF Racing reserves the right to repair, replace or issue an FMF credit for defective product at its discretion. Credits are valid for a period of one (1) year from issuance. No credit will be issued for labor or other costs incurred beyond the value of the original product. Product returned as a warranty after having been used, if found to be defective, is not valued at the full purchase price. A depreciated value will be estimated for used product. Product accepted as a warranty claim and repaired or replaced will be returned via UPS-ground freight no charge. Warranty excludes product that has been modified or where the product was improperly installed, abnormally used or misused. This limited warranty is in lieu of all other guarantees or warranties implied or expressed. This includes, without limitation, any warranties or merchantability and fitment for a particular purpose. We make no warranty as to products distributed by FMF Racing, expressed or implied. We will, however, pass on all warranties made by the manufacturer, who has sole responsibility for performing such warranties. A return authorization number must be issued by FMF Racing before product is returned. Returns must be sent back to FMF Racing freight prepaid. Proof of purchase, such as a copy of the original invoice, must accompany all warranty claims. Warranties will be honored to the direct purchaser only.